

Modeling the Frequency Response of Photovoltaic Inverters

E. C. Aprilia, V. Čuk, *Student Member, IEEE*, J. F. G. Cobben, P. F. Ribeiro, *Fellow, IEEE*, and W.L. Kling, *Member, IEEE*

Abstract—The increased presence of photovoltaic (PV) systems inevitably affects the power quality in the grid. This new reality demands grid power quality studies involving PV inverters. This paper proposes several frequency response models in the form of equivalent circuits. Models are based on laboratory measurements performed on five types of commercially available PV inverters, and fitted to obtain circuit parameters. The proposed models show a good agreement with the measured data.

Index Terms— distributed power generation, frequency response, grid-connected inverters, harmonic analysis.

I. INTRODUCTION

WITH the growing interest in energy generation from renewable sources, the number of installed photovoltaic (PV) systems will continue to grow. These systems can be either stand-alone or grid-connected. In both cases, the DC output generated by PV cells is converted to AC power using inverters. Conversion using power electronics results in non-sinusoidal current waveforms.

To smooth the output waveform, grid-interfaced inverters are equipped with filters to attenuate the lower and higher frequency components of the harmonics. The filter, however, might interact with grid impedance and add an additional resonance in the system. This situation can increase the local voltage distortion. This is especially true with ever-increasing interest and development in smart grid which is meant to accommodate more renewable energy sources in distribution networks. It leads to more PV modules and inverters in the networks, and this brings the need to analyze different aspects of PV interaction, including harmonic studies. A common

approach to study the behavior of PV inverters in the network is by simulating and analyzing the network using models of PV inverters and other network elements. The model used to represent PV inverters depends on the purpose of the study.

Examples of distribution network simulations with a large number of residential PV systems can be found in [1] and [2]. An adequate model of PV inverters found in harmonic studies is the Norton equivalent model (consisting of a harmonic current source with a parallel impedance), sometimes in series with an additional impedance [1]–[7], as depicted in Fig. 1. The series and parallel impedances usually simulate the output filter of the inverter, either represented by a resultant impedance ([1],[2],[4],[7]), or as physical components ([3],[5],[6]). The values of these impedances are also obtained from different approaches. Some are taken from typical values of commercial inverters ([1],[3]) while others are calculated from the nominal power of the inverters ([4],[5]). In [2], the current source is paralleled with a single capacitance.

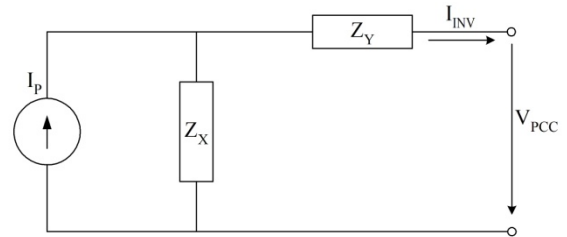

Fig. 1. An impedance and current source circuit as PV inverter model.

A different approach has been taken to calculate the parameter values of the impedance model in [8]. This approach measures the harmonic voltage across and the harmonic current at the terminal output of the inverter (see Fig. 1) for several particular frequencies. The parameter values for each frequency ($I_p(h)$, $Z_x(h)$, and $Z_y(h)$) are then calculated iteratively using the Newton-Raphson algorithm:

$$[I_p(h)Z_x(h)] - [I_{INV}(h)Z_x(h)] - [I_{INV}(h)Z_y(h)] = V_{PCC}(h) \quad (1)$$

where I_p is the harmonic current emitted by the inverter, I_{INV} is the harmonic current at the output of the inverter, V_{PCC} is the voltage at the connection point between the inverter and the grid, Z_x and Z_y are the series and parallel impedance, respectively.

This approach is using a look-up table (there will be a different model for every frequency) which is not favorable

E. C. Aprilia is a Master student in the Electrical Energy System (EES) group of the Eindhoven University of Technology, The Netherlands (e-mail: e.c.aprilia@student.tue.nl).

V. Čuk is a PhD candidate in the Electrical Energy System (EES) group of the Eindhoven University of Technology, The Netherlands (e-mail: v.cuk@tue.nl).

J. F. G. Cobben is currently working at Alliander and as a part-time assistant professor at the EES group of the Eindhoven University of Technology, The Netherlands, (e-mail: j.f.g.cobben@tue.nl).

P. F. Ribeiro is an associate professor at the EES group of the Eindhoven University of Technology, The Netherlands, (e-mail: p.f.ribeiro@tue.nl).

W.L.Kling is a full-time professor and the head of the Electrical Energy Systems group at the Eindhoven University of Technology, the Netherlands, (e-mail: w.l.kling@tue.nl).

because a large number of iterations are required to solve 3 unknown variables from only one equation. Moreover, since there are different models for different frequencies and the impedance value does not represent a particular element (capacitance/inductance), it is not possible to estimate the resonant frequency from this approach.

This paper presents an alternative impedance circuit as a PV inverter model, in order to investigate the relationship between the inverter and the network in the frequency domain. An experiment is set-up to measure the frequency response of inverters and an analytical approach is used to create the impedance model.

II. MEASUREMENT SETUP

The PV inverter impedance is estimated from harmonic voltages generated by a voltage source and the current responses of the inverter, as shown in Fig. 2. The impedance is calculated as:

$$\overline{Z}_h = \frac{\overline{V}_h - \overline{V}_{h0}}{\overline{I}_h - \overline{I}_{h0}}, 2 \leq h \leq 50 \quad (2)$$

where Z_h is the impedance, V_h is harmonic voltage source, I_h is the harmonic current at the output of the inverter, V_{h0} and I_{h0} are measured harmonic voltage and current when the fundamental voltage is applied without distortion.

The analog harmonic current and voltage are measured and sampled by a PC-based scope and analytically transformed into frequency domain with DFT using Matlab.

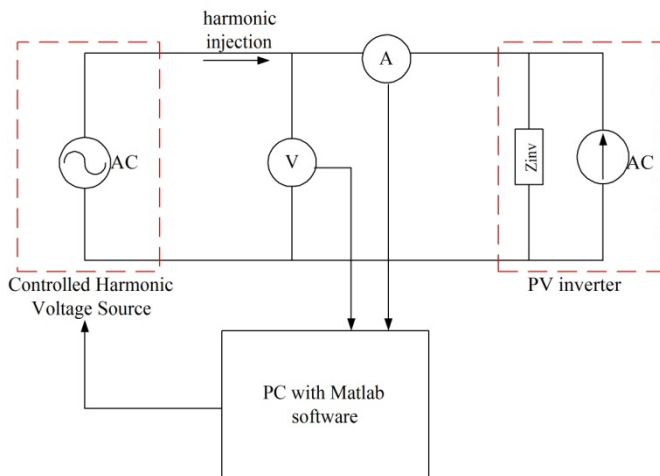

Fig. 2. Measurement schematic.

The harmonic source is varied in amplitude and phase angle so that for every frequency several values of impedance are obtained. It is expected that these values are convergent and therefore can be averaged. The average impedance of every frequency is then plotted against the frequency to get impedance-frequency profile, from which the impedance model will be build. To obtain better profile, measurement is also done for interharmonic frequencies (from 75 until 2475 Hz, with a step of 50 Hz). The amplitudes of the voltage stimuli are chosen not to exceed the standards for harmonic

voltage level in LV network (EN50610 and IEC61000-3-6).

III. MEASUREMENT RESULTS

The experiment is done on 5 commercial PV inverters: three single-phase inverters, one power router, and one three-phase inverter. Single-phase inverters (Inverter1, Inverter2, and Inverter3) have nominal output powers of 1200 W, 1500 W, and 1500 W, respectively. The single-phase power router has a nominal power of 5000 W, and the three-phase inverter 2600 W. Although the latter needs a 3-phase connection, it only feeds-in to the grid via 1 phase (hence it can be treated as a single-phase inverter).

A. Single-phase (SP) Inverters

All three SP inverters have impedance profile similar to that of a capacitor (i.e. the impedance is inversely proportional to the frequency). Thus, a single capacitor is adequate to model the impedance. For Inverter2, however, a better fitting is obtained when the model includes a resistor in series with the capacitance. The impedance profile of each of the inverters is shown in Fig. 3, Fig. 4, and Fig. 5, while the impedance models of all three inverters are shown in Fig. 6. The impedance profile consists of harmonic and interharmonic measurement results. All three inverters are measured at the same input power, 900Wdc.

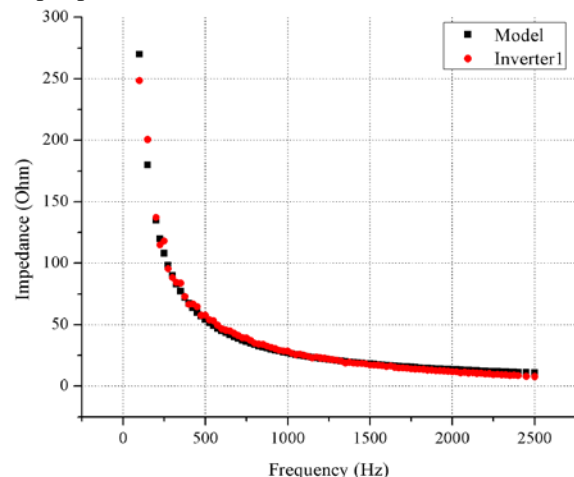

Fig. 3. The impedance profile of Inverter1 and the model.

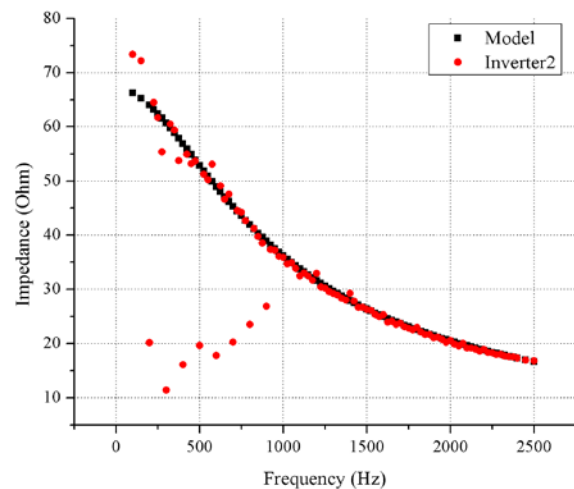

Fig. 4. The impedance profile of Inverter2 and the model.

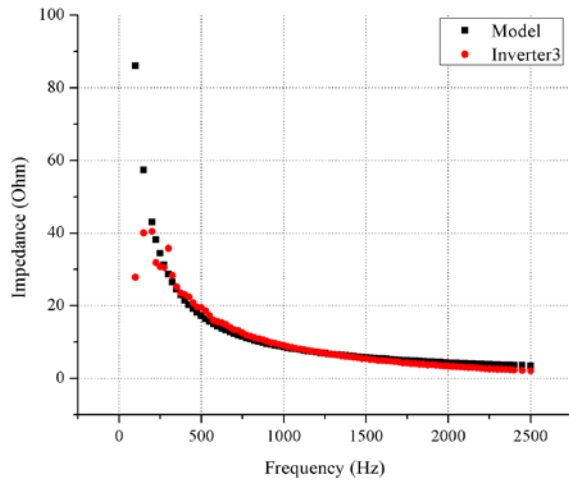

Fig. 5. The impedance profile of Inverter3 and the model.

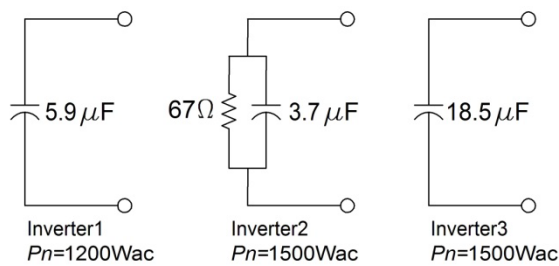

Fig. 6. The impedance models of SP inverters.

B. Single-phase (SP) Power Router

A power router operates in a slightly different way from most commercial PV inverters complying with “anti-islanding” regulation. A power router can be connected to a DC storage that delivers the power during grid faults. Although in principal it works as a SP inverter, the impedance profile differs from the other SP inverters; there is a parallel resonance at $h=33$. This happens due to the different topology of the filter inside the inverter. Only harmonic measurement results are presented here because it is not possible to do interharmonic measurements on this inverter. Interharmonic components of the voltage trigger the protection system of the power router.

Due to its unique profile, it is difficult to create the impedance model that fits very well. A good estimation, however, was obtained based on below considerations:

- the resonance is parallel, at $f=1650\text{Hz}$,
- a series resistor determines the values at lower harmonics,
- a damping resistor determines the peak values, and
- since lower harmonics are more common in the grid, more attention is given to fit the measurement curve at lower harmonics, as shown in Fig. 7.

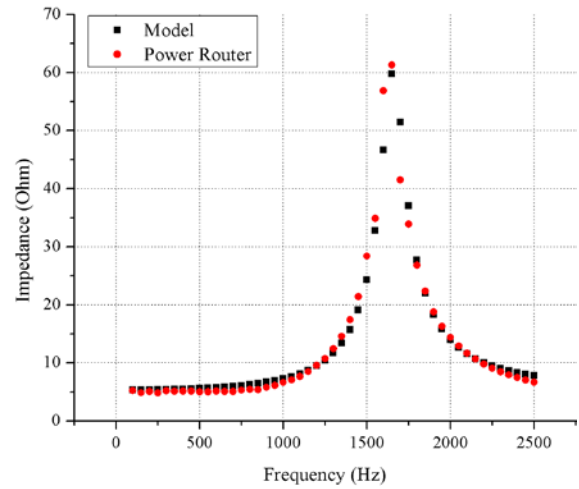

Fig. 7. The impedance profile of SP power router and the model.

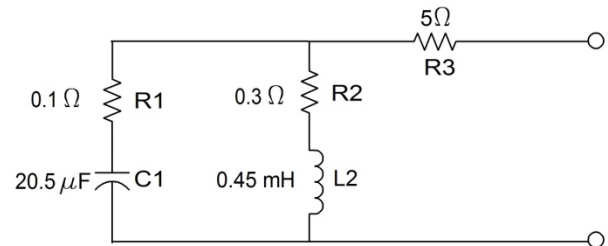

Fig. 8. The impedance model of SP power router.

C. Three-phase (TP) Inverter

Although in principal this TP inverter works like a SP inverter (because it feeds-in to one phase), the impedance profile looks different from other SP inverters. It still has the negative characteristic (the impedance decreases when the frequency increases) but it is unlike a capacitor behavior. Therefore, a complex impedance model like that of the power router is applied with different parameter values. Fig. 9 shows the impedance model and Fig. 10 shows the impedance profile.

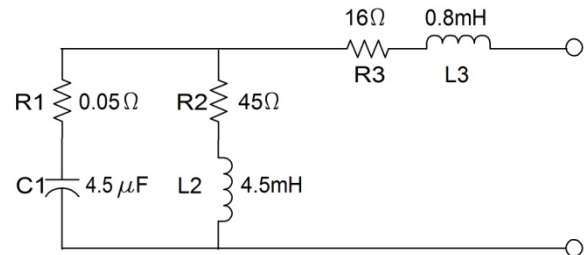

Fig. 9. The impedance model of TP inverter.

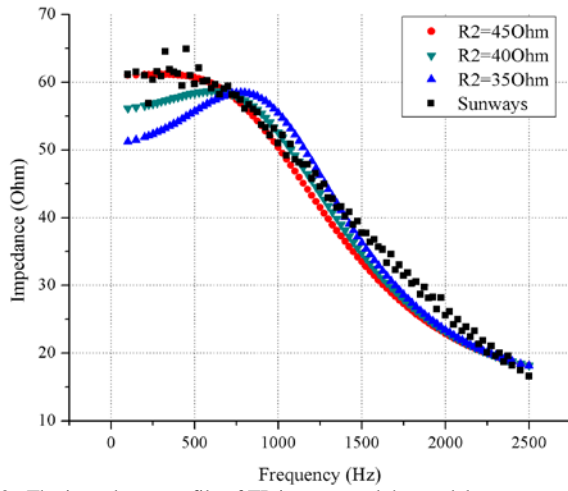

Fig. 10. The impedance profile of TP inverter and the model.

IV. GENERAL MODEL AND AGGREGATED MODEL

To keep all controlled variables similar among different SP inverters, all measurements are carried-out at 900Wdc input power. Looking at the similarity between the three SP inverter output impedances, a simple general model to represent the output impedance of commercial SP inverters for 1-2kW can be deduced. It is a single capacitor with values ranging between 3.7-18.5 μ F. Typical values of output capacitor of commercial 1-3kW PV inverters are between 0.5-10 μ F, as reported in [2]. A single capacitance value cannot represent every inverter but using several values from the range is adequate. Note that the TP inverter in this experiment cannot be taken as a general case of SP inverter in 2-3kW power class because although it feeds in via 1 phase, it still needs 3-phase connection.

As for higher power class SP inverters, the model shown for the TP inverter and power router can serve as a general representation of the output impedance. The parameter values will surely be different from one inverter to the others and the exact parameter values can only be obtained from measurement. However, a look-up table of parameters for different power class (e.g. 4kW, 5kW) can be build which speaks for all inverters in that particular power class. If one wants to make a network simulation using this model, one can use the impedance circuit depicted in Fig. 11 with parameters from the look-up table.

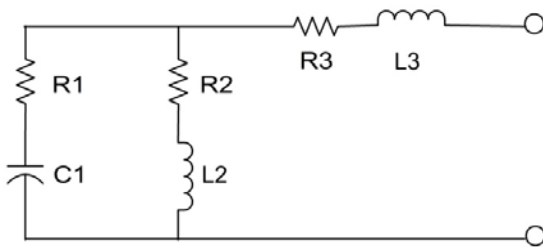

Fig. 11. General model to represent a single phase PV inverter

When multiple inverters are connected to the grid, the parallel capacitance value will be higher and it might result in a lower resonant frequency. It is important, therefore, to

include a model for an aggregation of inverters in the network simulation. It is adequate to use the same topology of simple and complex impedance circuit already presented; the only difference will be the parameters which result from parallel summation of individual parameters.

To validate this, an experiment was carried-out to measure the output impedance of all three SP inverters connected in parallel. Fig. 11 shows the result of harmonic and interharmonic measurement.

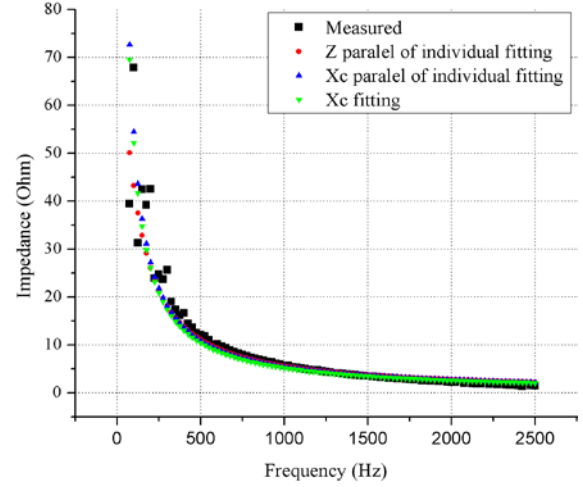

Fig. 12. The impedance profile of an aggregation of three SP inverters.

Also shown in Fig.11 is the resultant impedance from the inverter's individual impedances connected in parallel, calculated by Eq. 3, where Z_p is the resultant impedance, $X_{C,1}$ is Inverter1's capacitive reactance, $Z_{S,2}$ is the series of resistor and capacitor of Inverter2, and $X_{C,3}$ is Inverter3's capacitive reactance. As with individual measurement of SP inverters, a curve fitting was also applied to the impedance and the curve of a single capacitor fits the measurement curve the best. The capacitance found from curve fitting is 30.5 μ F, which is close to the resultant capacitance of paralleled inverters 28.1 μ F (summation of 5.9 μ F, 3.7 μ F, and 18.5 μ F). The impedance profile from both capacitance values are shown in blue and green marker, respectively.

$$\frac{1}{Z_p} = \frac{1}{X_{C,1}} + \frac{1}{Z_{S,2}} + \frac{1}{X_{C,3}} \quad (3)$$

The influence of each individual inverter is also seen in the aggregated model. Fig. 4 shows significant discrepancies between measured and model impedance of Inverter2, particularly at lower frequencies. It translates to discrepancies between measured and calculated impedance of the aggregated model at lower frequencies, only much less because the other two inverters damp this phenomenon.

V. CONCLUSIONS

To understand the influence of PV inverters on harmonic voltages in low-voltage networks, it is useful to simulate the network including a proper inverter model. This paper has proposed several equivalent circuit models that can be used to represent the dominant resonant frequency of the inverter. The

model is developed from voltage and current measurements at the output of the inverter. Measurements are done on harmonic and interharmonic frequencies to estimate the influence of inverters harmonic suppression. The results of measurements on harmonic and interharmonic frequencies are in good agreement.

From the impedance-frequency plot, the models represent the inverters' characteristic adequately on most of the frequency range observed. The discrepancies come from several assumptions made before the measurement:

- the line impedance is zero: this is not true although it is really small,
- there are two harmonic sources (voltage source and inverter current): theoretically it can be solved using the superposition theorem by eliminating one harmonic source each time but it is not applicable because it is not possible to operate the inverter without its harmonic current source.

A general model can be deduced using parameters that represent every power class. An aggregated model is also presented using the same topologies presented for individual inverter with parameters calculated from the parallel connection between the inverters. This model has been validated during the experiment. Another interesting thing found from the experiment is that the measured impedance is not influenced by the power rating of the inverter during measurement.

To have a complete Norton model of a PV inverter, further measurements and modeling of the harmonic currents emitted by the inverter needs to be done. With this complete model, one can simulate harmonic flow stemming from PV inverters in the network.

VI. REFERENCES

- [1] E. Vasanasong and E. D. Spooner, "The effect of net harmonic currents produced by numbers of the Sydney Olympic Village's PV systems on the power quality of local electrical network," in *Proc. 2000 International Conference on Power System Technology*, pp. 1001-1006.
- [2] J. H. R. Enslin and P. J. M. Heskes, "Harmonic interaction between a large number of distributed power inverters and the distribution network," in *Proc. 2003 IEEE Power Electronics Specialist Conf.*, pp. 1742-1747.
- [3] J. L. Agorreta, M. Borrega, J. López, and L. Marroyo, "Modeling and Control of N-Paralleled Grid-Connected Inverters With LCL Filter Coupled Due to Grid Impedance in PV Plants," *IEEE Trans. Power Electronics*, vol. 26, pp. 770-785, Mar. 2011.
- [4] P. J. M. Heskes, P. M. Rooij, J. F. G. Cobben, and H. E. Oldenkamp, "Estimation of the potential to pollute the electricity network with harmonics due to the use of small micro generators with inverters," ECN, Tech. Rep. ECN-C--04-087, Aug. 2004. [Online]. Available: <http://www.ecn.nl/docs/library/report/2004/c04087.pdf>
- [5] J. N. Paquin and D. Turqotte, "PV Inverter Modelling for Power Quality Studies," CANMET Energy Technology Centre, Varennes, QC, Tech. Rep. CETC 2007-202 (TR), Nov. 2007.
- [6] Y. Li, P. Jing, Y. Luo, B. Zhang, C. Mao, and X. Ruan, "A study on dynamic power flow caused by the grid-connected PV systems," in *Proc. 2010 IEEE International Symposium on Power Electronics for Distributed Generation Systems (PEDG)*, pp. 76-80.
- [7] F. Wang, J. L. Duarte, and M. A. M. Hendrix, "Analysis of harmonic interactions between DG inverters and polluted grids," in *Proc. 2010 IEEE International Energy Conference and Exhibition*, pp. 194-199.
- [8] C. Limsakul, A. Sangswang, D. Chenvidhya, M. Seapan, B. Meunpinij, N. Chayavanich, and C. Jivacate, "An impedance model of a PV grid-connected system," in *Proc. 2008 IEEE Photovoltaic Specialists Conf.*, pp. 1-4.

- [9] J. P. Rhode, A. W. Kelley, and M. E. Baran, "Complete characterization of utilization-voltage power system impedance using wideband measurement," *IEEE Trans. Industry Applications*, vol. 33, pp. 1472-1479.

VII. BIOGRAPHIES



Ernauli Aprilia received her Bachelor degree in Electrical Engineering from Institut Teknologi Bandung, Indonesia, in 2007. Since 2010 she is pursuing a Master degree in Sustainable Energy Technology in Eindhoven University of Technology. Her graduation project is carried out at Electrical Energy Systems group.



Vladimir Ćuk received his dip. ing. (M.Sc.) degree in electrical engineering from the School of Electrical Engineering, University of Belgrade, Serbia, in 2005. During 2006-2009 he was with the Electrical Engineering Institute "Nikola Tesla" in Belgrade. Since 2009 he is a PhD candidate at the Electrical Energy Systems group of the Eindhoven University of Technology. His main research topic is electrical power quality.



Sjef Cobben was born in Nuth, Netherlands, in 1956. He received the Bachelors degree in Electrical Engineering from the Technical University of Heerlen in 1979. In 2002 he received the Masters degree in Electrical Engineering from Eindhoven, University of Technology (TU/e).

In 1979 he joined NUON, one of the largest energy organizations in the Netherlands. Since 2000 he is working for the Dutch grid operator Liander, where he is engaged in Power Quality problems and safety requirements. From 2003 to 2007 he worked part time on a Ph.D. project about "intelligent grids" with as special topic Power Quality problems. Sjef Cobben is member of several national and international standardization commissions about requirements for low and high voltage installations and characteristics of the supply voltage. He is author of several books about power quality and low voltage installations. Since 2007 he is working as assistant professor at the University of Technology in Eindhoven, Netherlands.



Paulo Ribeiro received a BS in Electrical Engineering from the Universidade Federal de Pernambuco, Recife, Brazil in 1975; completed the Electric Power Systems Engineering Course with Power Technologies, Inc. (PTI), in 1979; and received Ph.D. from the University of Manchester, Manchester, UK in 1985. He is an Associate Professor of Electrical Engineering at the Technical University of Eindhoven, Eindhoven, the Netherlands. His research interests include power electronics, power quality, system modeling and simulation.



Wil Kling received his M.Sc. degree in Electrical Engineering from the Eindhoven University of Technology, Eindhoven, the Netherlands, in 1978. Since 1993, he has been a part-time Professor with the Delft University of Technology, the Netherlands in the field of Electrical Power Systems. Up till the end of 2008 he was also with TenneT, the Dutch Transmission System Operator, as senior engineer for network planning and strategy. Since Dec. 2008, he has been appointed Chair of the Electrical Energy Systems group, Eindhoven University of Technology. He is leading research programs on distributed generation, integration of wind power, network concepts and reliability issues.

Prof. Kling is involved in scientific organizations such as CIGRE and the IEEE. As Netherlands' representative, he is a member of CIGRE Study Committee C6 on Distribution Systems and Dispersed Generation, and the Administrative Council of CIGRE.